

Installation Support • Soporte de instalación • Support d'installation

**Personal Assistance, Product Specs, &
"How-to" Questions:**

Asistencia personal, especificaciones del producto y preguntas sobre "cómo hacerlo":

Aide personnelle, spécifications du produit et questions « pratico-pratiques » :

1-800-340-7608

www.pfisterfaucet.com/International

▲ WARNING / ADVERTENCIA / AVERTISSEMENT

To reduce the risk of injury or property damage, read all instructions before installing product. Wear safety goggles. Product must be installed in accordance with all state & local plumbing & building codes. Call a professional if you are uncertain about installing this product.

Para disminuir el riesgo de lesiones o daños a la propiedad, lea todas las instrucciones antes de instalar el producto. Utilice gafas de seguridad. El producto deberá instalarse de acuerdo con la normativa de plomería y construcción estatal y local. Llame a un profesional si no está seguro sobre cómo instalar este producto.

Pour réduire le risque de blessures ou de dommages, lire toutes les instructions avant d'installer le produit. Portez des lunettes de sécurité. Il faut installer le produit en respectant tous les codes de construction et de plomberie locaux et d'état. Appelez un professionnel si vous n'êtes pas certain de la façon d'installer ce produit.

Required Tools • Herramientas necesarias • Outils nécessaires



Additional Helpful Tools

Otras herramientas útiles
Outils supplémentaires utiles

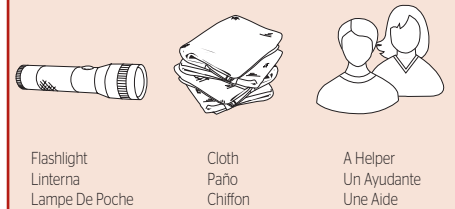

Parts in the Box • Piezas en la caja • Pieces dans la boîte

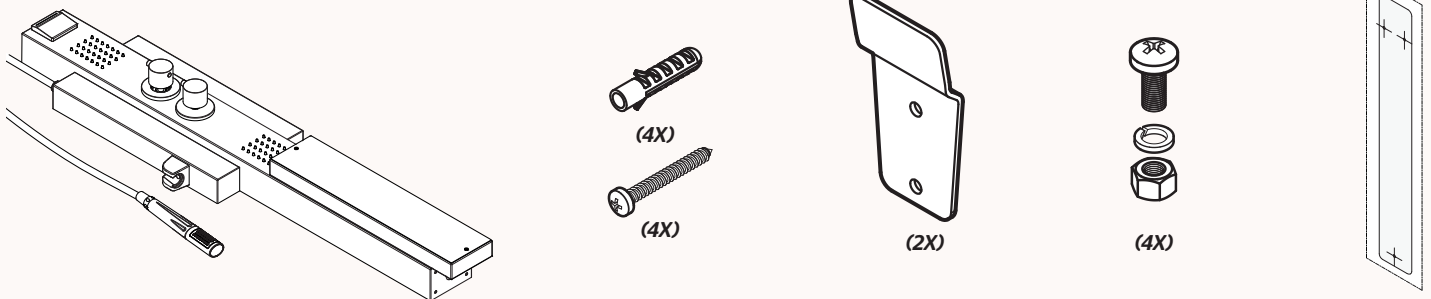

1 Turn Off Water Supply • Cierre el suministro de agua • Couper l'alimentation en eau

! Locate the water supply valves and shut off the water supply to shower panel installation area.

Ubique las entradas del suministro de agua y cierre las válvulas de suministro de agua.

Recherchez les entrées d'approvisionnement et fermer les robinets.

2 Preparation

Preparación
Préparation



Philips Screwdriver
Destornillador de estrella
Tournevis Philips

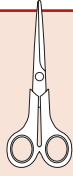

Scissors
Tijeras
Ciseaux

No Parts Required for This Step
No se necesitan piezas para este paso
Pas de pièce nécessaire pour cette étape

2A Unpack

Desempaquete
Déballez

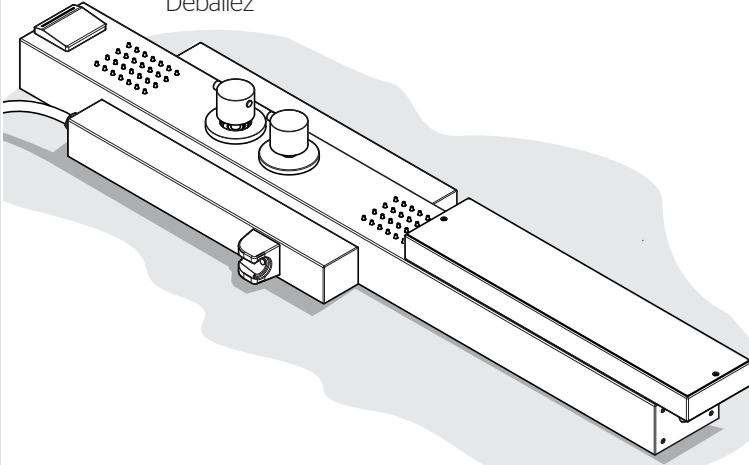

2B

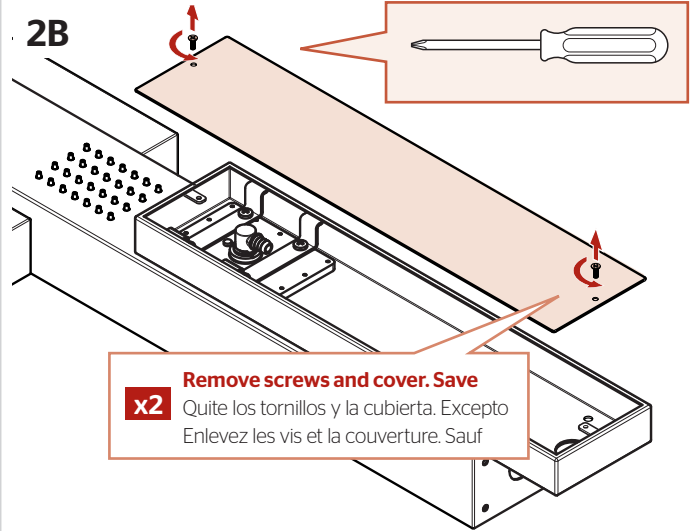

x2 Remove screws and cover. Save
Quite los tornillos y la cubierta. Excepto
Enlevez les vis et la couverture. Sauf

2C

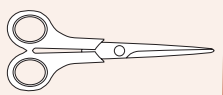
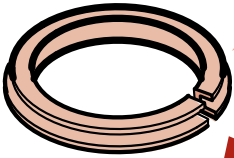

Top assembly
Asamblea superior
Assemblée supérieure

Wall assembly
Asamblea de la pared
Assemblage de le mur

Keep
Mantener
Garder

2D

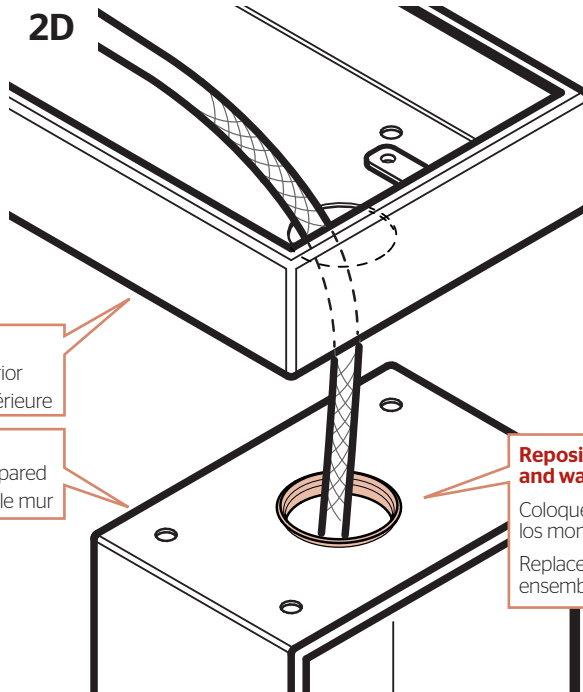

Reposition gasket to seal both top and wall assemblies

Coloque de nuevo la junta para sellar los montajes de la tapa y de la pared
Remplacez la garniture pour sceller des ensembles de dessus et de mur

1

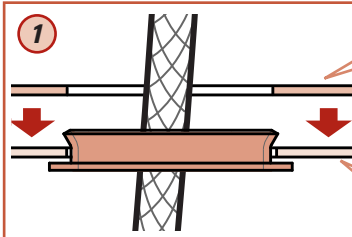

Top assembly
Asamblea superior
Assemblée supérieure

Wall assembly
Asamblea de la pared
Assemblage de le mur

2

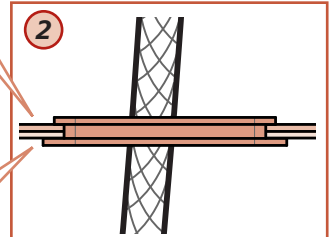

2 Preparation (Continued)

Preparación (Continuado)

Préparation (Continu)



Philips Screwdriver
Destornillador de estrella
Tournevis Philips

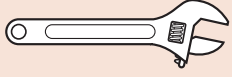

Adjustable Wrench
Llave ajustable
Clé à mollette



(4X)

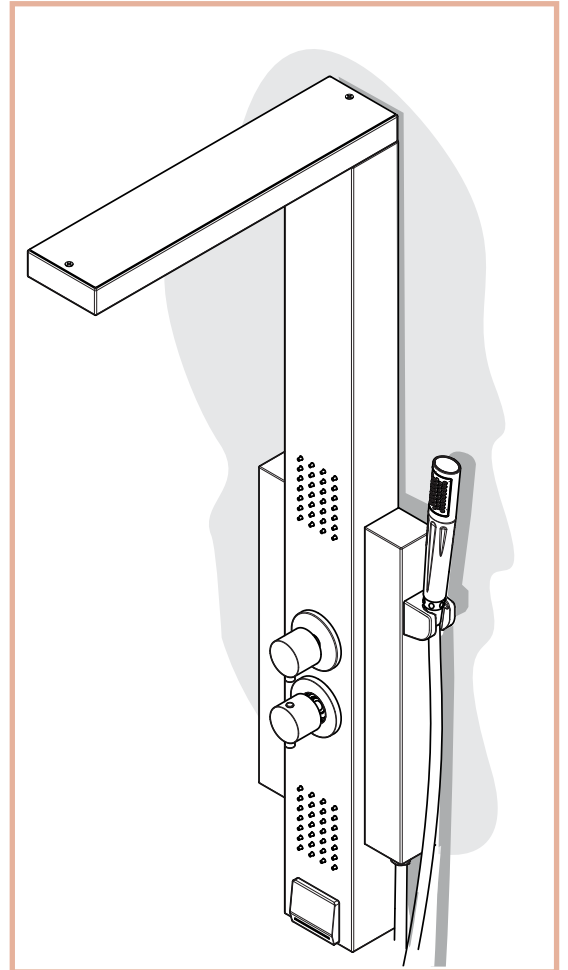
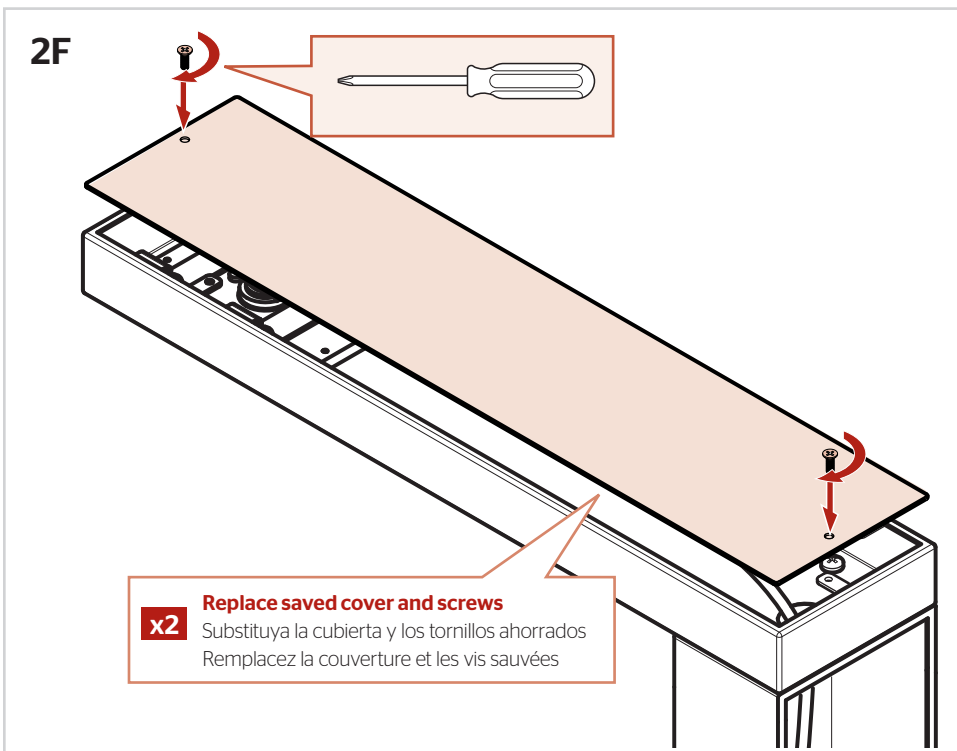
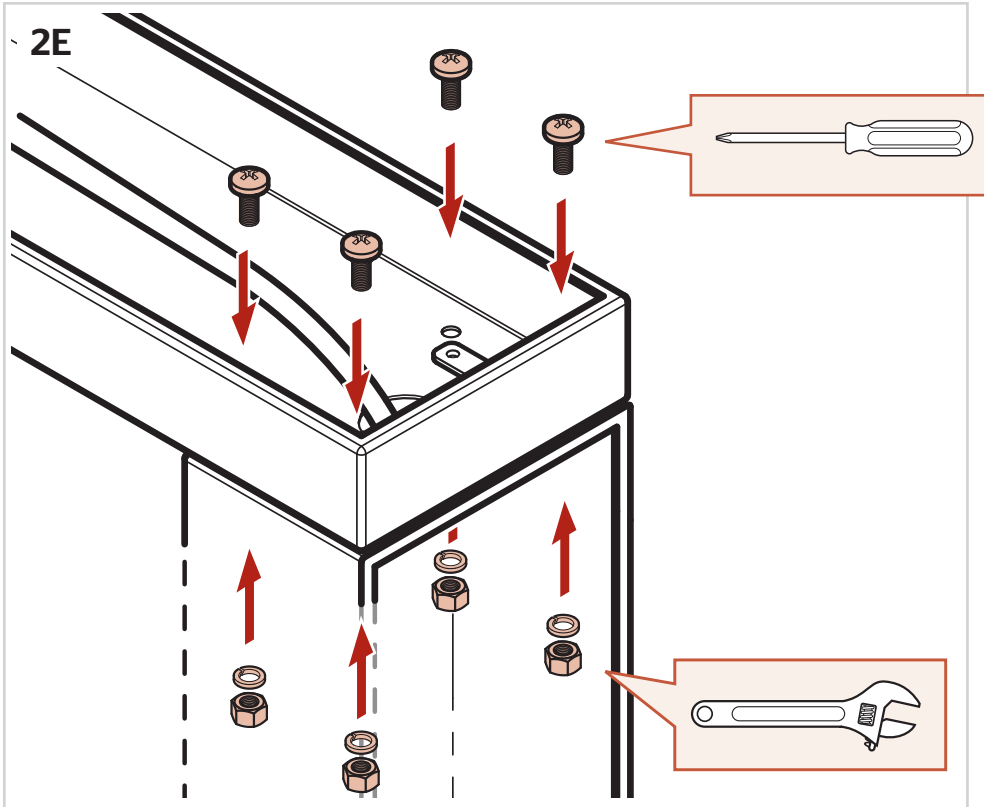

Recommended Dimensional Layout

Disposición recomendada dimensional

Disposition recommandée dimensionnelle

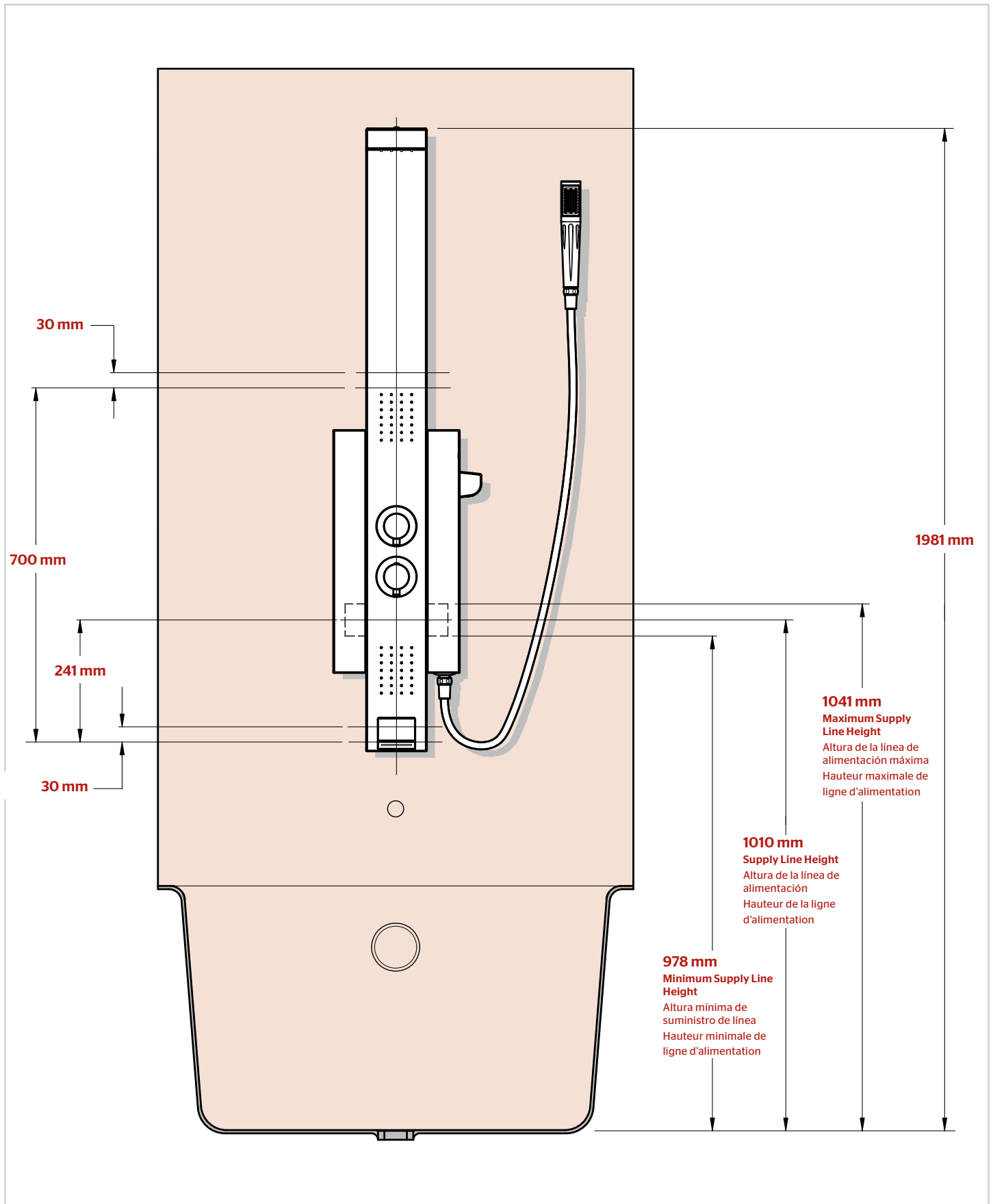

3 Bracket Locations

Localizaciones del soporte

Endroits de parenthèse

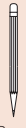

Pencil
Lápiz
Crayon

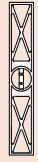

Level
Burbuja de nivel
Niveau à Bulle



3A

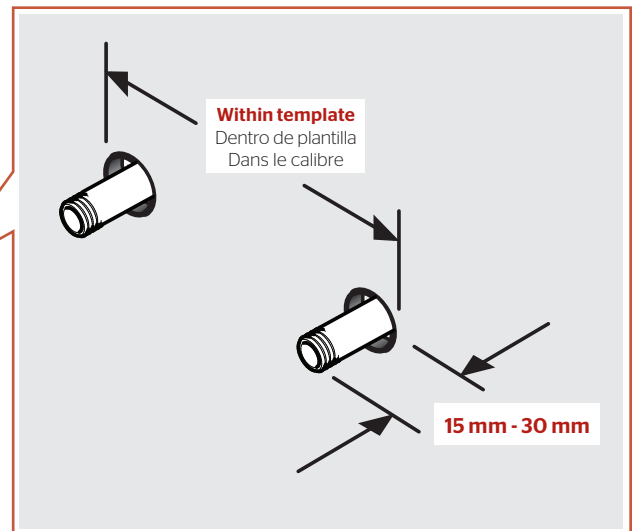
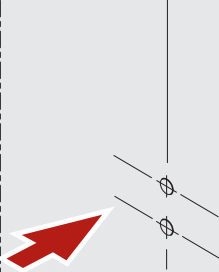
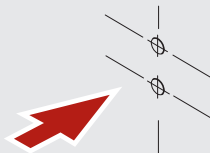
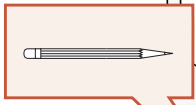
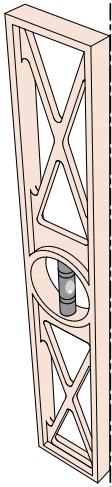
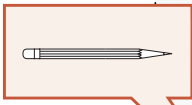





4

Bracket Installation

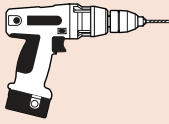
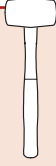
Intalación del soporte

Installation des supports de fixation

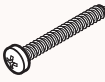
			
Safety Goggles Anteojos de seguridad Lunettes de sécurité	Power Drill Taladro Eléctrico Foreuse Électrique	Mallet Mazo Maillet	Phillips Screwdriver Destornillador de estrella Tournevis Philips

		
(4X)	(4X)	(2X)

4A

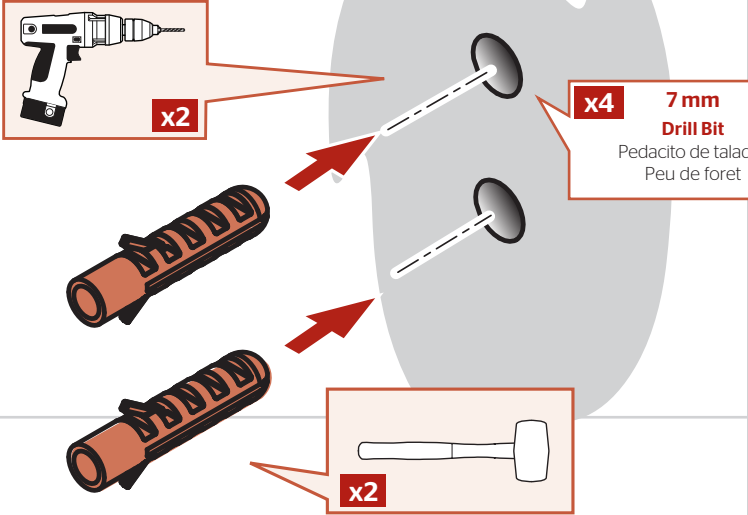

x2

x4 7 mm Drill Bit
Pedacito de taladro
Peu de foret

x2

4B

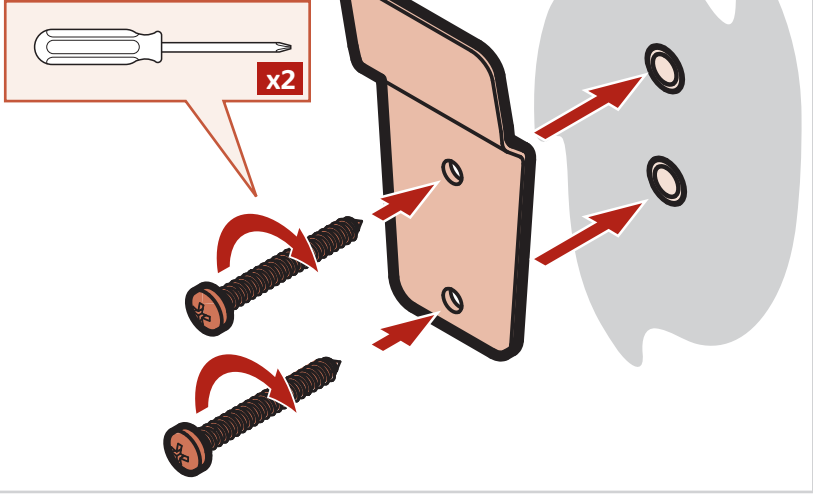

x2

4C

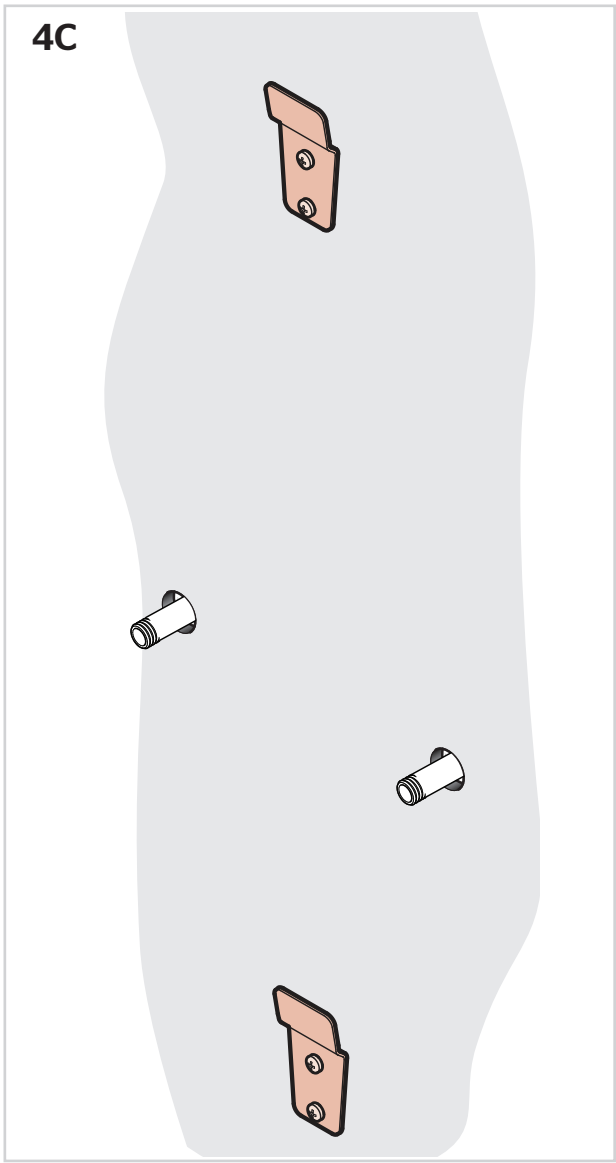

5

Connect Water Supply Lines and Mount

Conecte las tuberías de suministro de agua y montaje

Raccorder les conduites d'alimentation en eau et bâti



PTFE plumber's tape
Cinta para plomería PTFE
Ruban PTFE de plombier

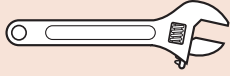

Adjustable Wrench
Llave ajustable
Clé à mollette

No Parts Required for This Step
No se necesitan piezas para este paso
Aucune pièce nécessaire pour cette étape

5A

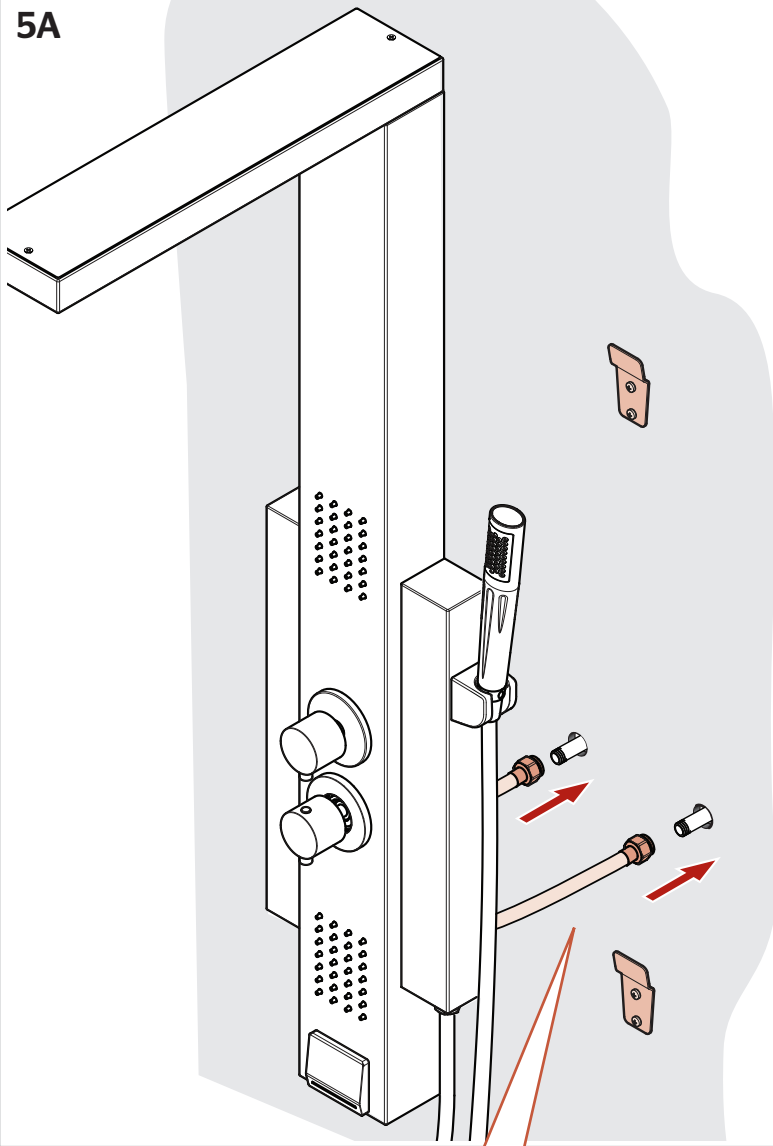

x2

Mount to Bracket
Montar en el soporte
Monter sur le support

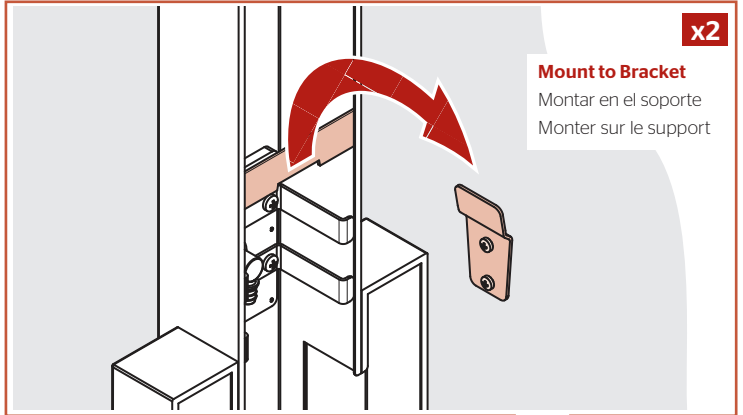

5B

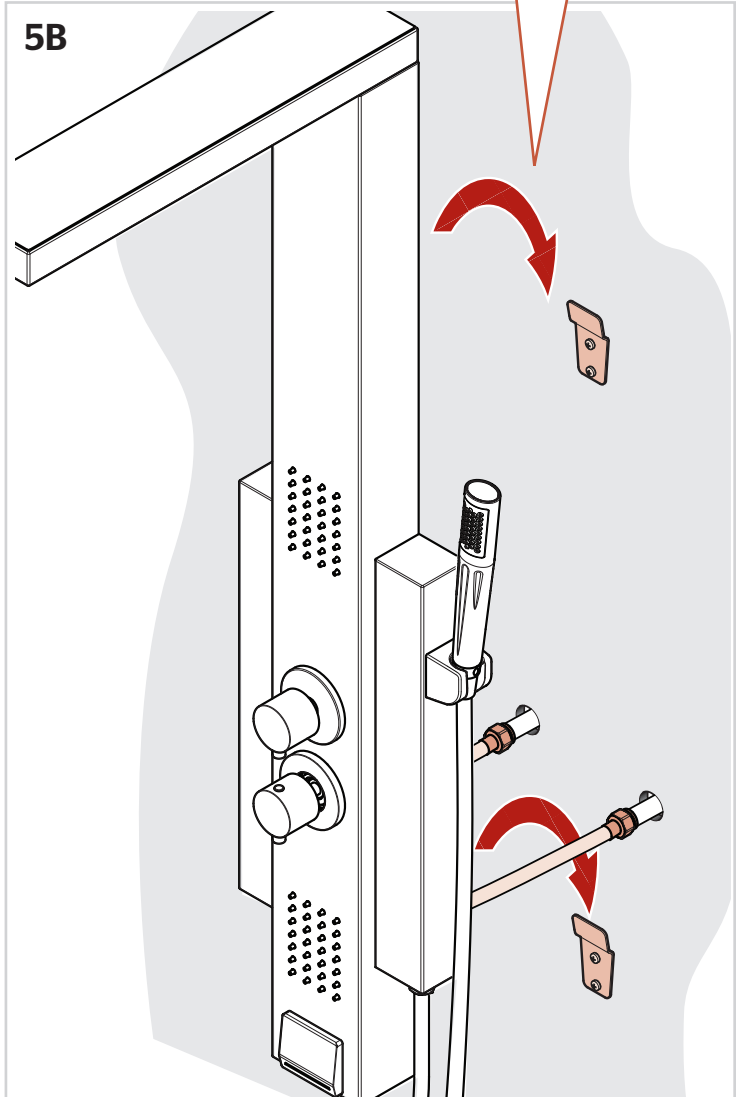

x2

Hot & Cold
Caliente y fría
Chaud et froid

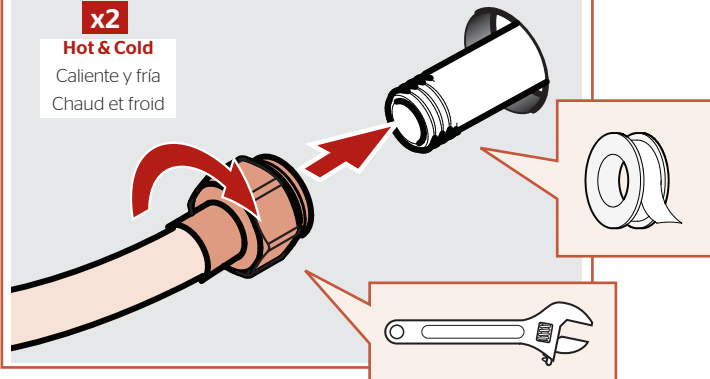

6

Turn On Water & Confirm Proper Installation

Active el suministro de agua y confirme que la instalación está adecuadamente efectuada

Ouvrez l'eau et confirmez que l'installation est correcte

No Tools Required for This Step
No se necesitan herramientas para este paso
Pas d'outil nécessaire pour cette étape

No Parts Required for This Step
No se necesitan piezas para este paso
Aucune pièce nécessaire pour cette étape

Shower Panel Functions

Funciones del panel de la ducha

Fonctions de panneau de douche

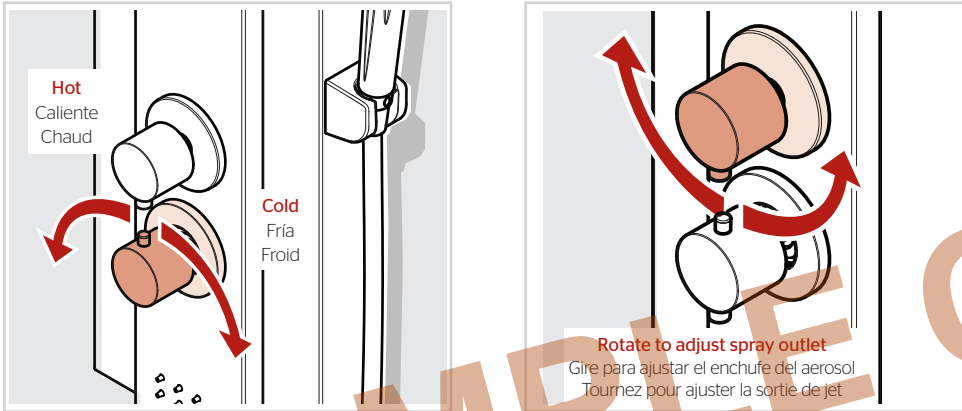

Spray Outlets • Enchufes del aerosol • Sorties de jet

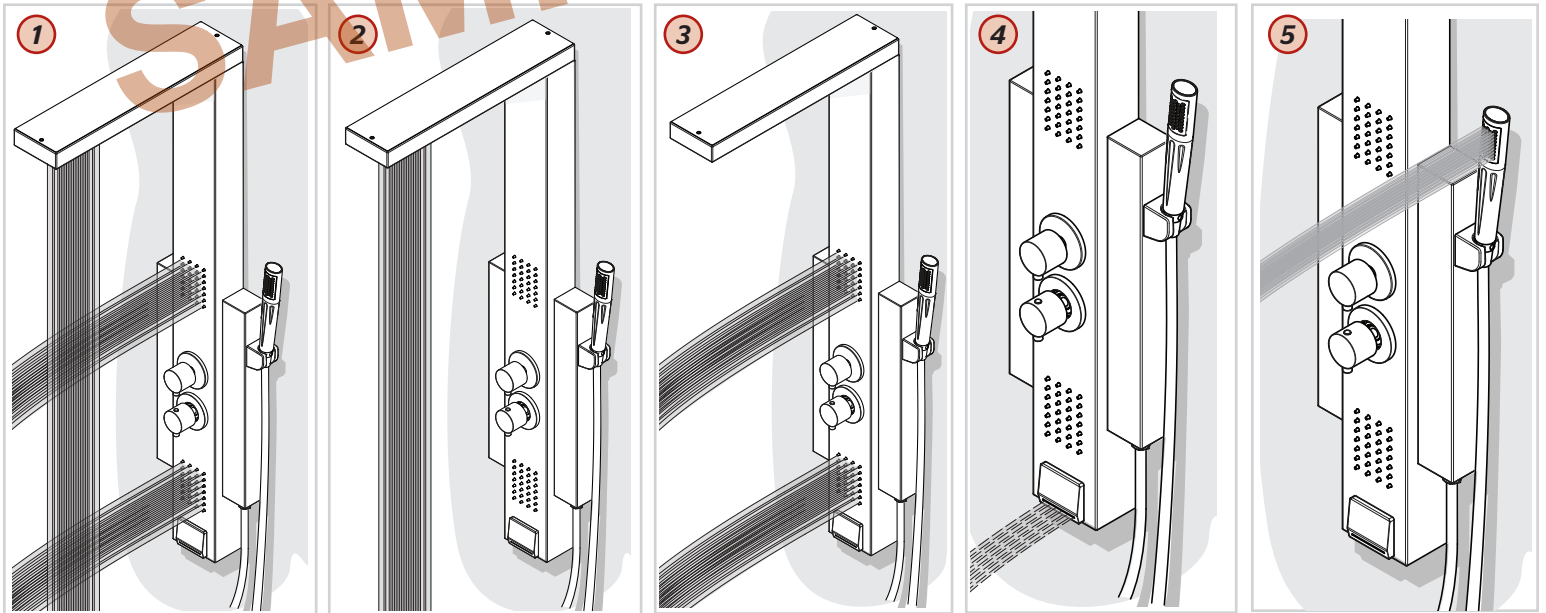

For Additional Installation Help:
Para la instalación adicionales de ayuda:
Pour aider à l'installation supplémentaires:

Pfister

1-800-340-7608

www.pfisterfaucets.com/international